

Instruction Sheet

AD-450

CAT. NO. 71146-000, 200, 300

AMPLIFIED BROADBAND UHF

ANTENNA SPLITTER

PN 802453

General Description

The AD-450 Amplified Broadband Splitter makes it possible to operate four UHF wireless diversity microphone receivers on four separate frequencies using only two antennas. It also features a high degree of output isolation; a necessity in multi-frequency systems to prevent intermodulation.

The AD-450 Splitter is compatible with all Telex UHF diversity wireless receivers.

SPECIFICATIONS

Frequency Range.....	520-760 MHz
3rd Order Intercept Output.....	greater than 28 dbm
Net Gain.....	greater than 2 dB
Noise Figure.....	less than 4 dB
Output Isolation.....	greater than 15 dB
Connectors, Antenna.....	Standard TNC receptacles
Connectors, Power.....	2.1 mm x 5.5 mm
Indicators, Power.....	Green LED
Power Supplies.....	INPUT: 110VAC 60 Hz OUTPUT: 15 VDC 1.3A INPUT: 230 VAC 50 Hz OUTPUT: 15 VDC 1.5A

Product Features

The AD-450 is equipped with TNC type connectors. Coaxial cables are also supplied for splitter to receiver antenna jack connections. The AD 450 has an external AC power supply. Power out jacks and cables are provided to supply up to four receivers thus eliminating excess power supply clutter.

A green LED mounted on the front panel indicates power ON. A "rocker" type switch controls power to the splitter and receivers.

Rack panel mounting brackets allow the AD-450 to be mounted in a standard 19 inch equipment rack. "knock outs" in the bracket allow front connection of antenna cables.

System Configuration

Figure 2 illustrates the typical system configuration using the AD-450.

Figure 3 illustrates an arrangement where two splitters have been cascaded. By connecting one of the outputs of the first splitter to the antenna inputs of the second splitter, three additional receivers may be driven by a single pair of antennas.

SPECIAL NOTE: In any system, unused splitter outputs should be terminated with a 50 ohm "dummy load". See the accessories listing at the end of this manual

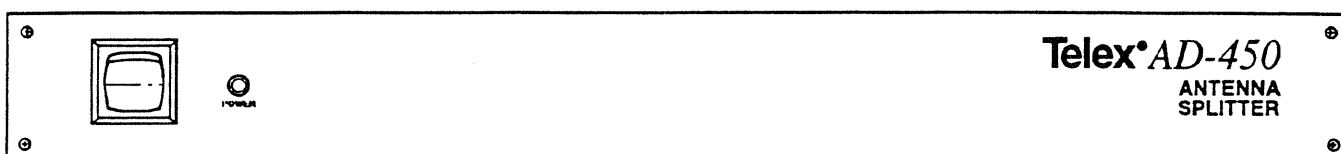

Front View

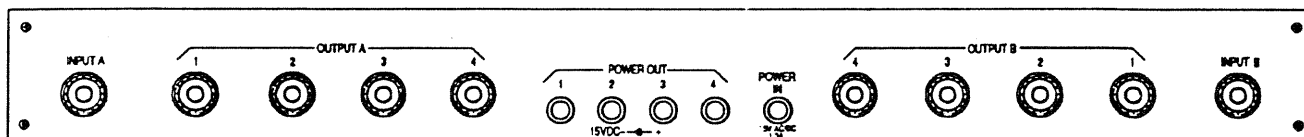

Rear View

Figure 1
Front and Rear View

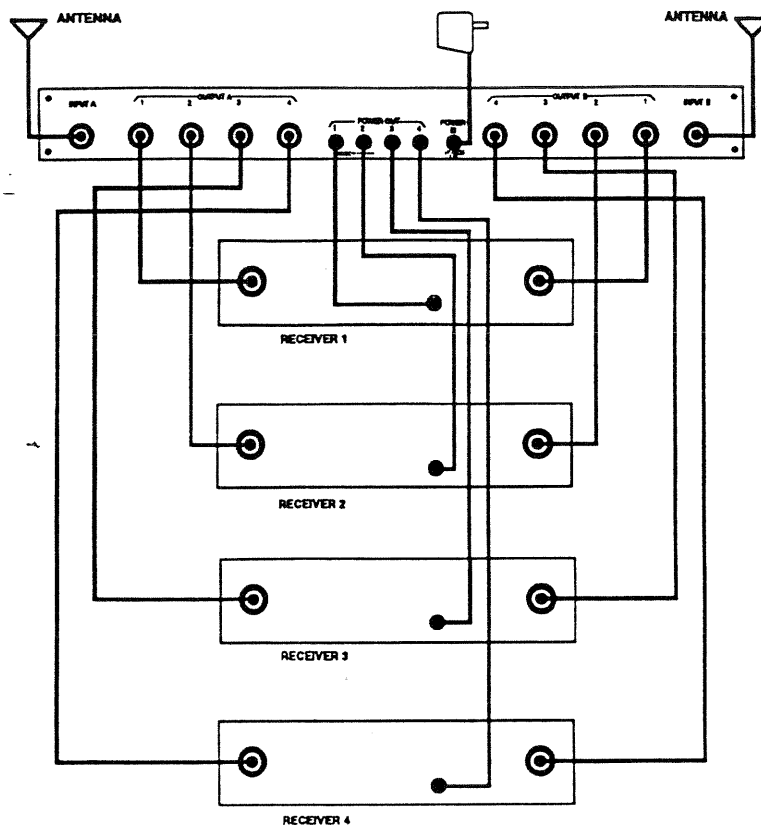
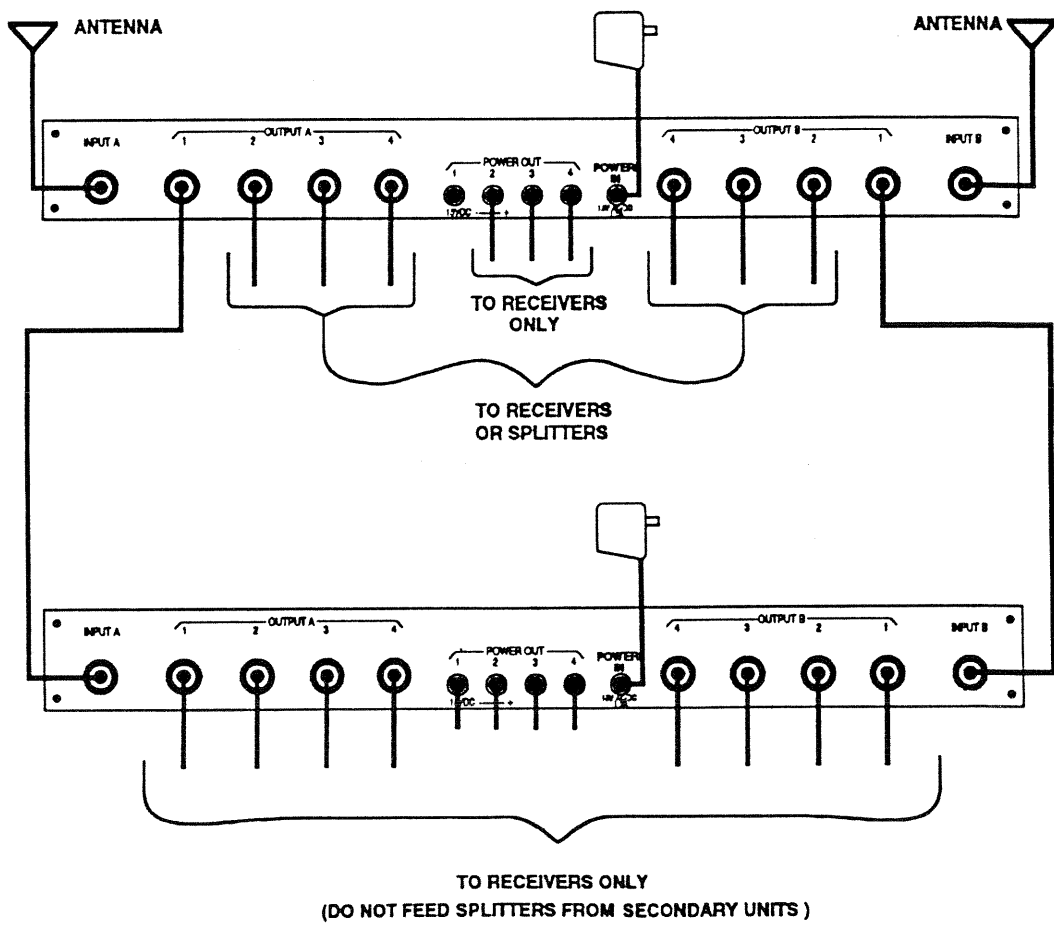

Figure 2
System Configuration



TO RECEIVERS ONLY
(DO NOT FEED SPLITTERS FROM SECONDARY UNITS)

Figure 3
Cascading

Power Supply

The AD-450 is equipped with a power supply that is rated with a minimum output of 15 VDC at 1.3 amps. The power cables provided to hook up receivers have 2.1 mm x 5.5 mm barrel connectors on both ends.

Antenna Requirements

The AD-450 may be used with a variety of antennas. For best results, use a pair of ALP-450 directional log periodic antennas. See Figure 4. The ALP-450 offers the best performance and broadest bandwidth available.

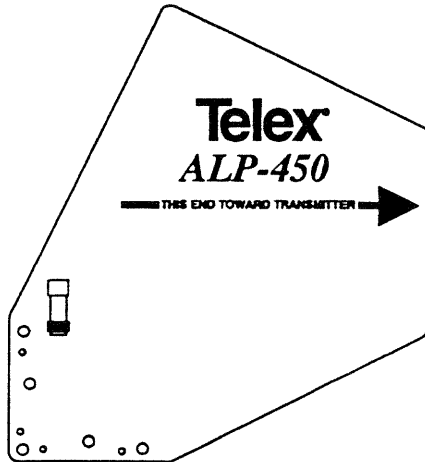

ALP-450

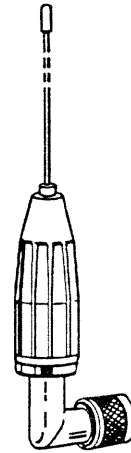

1/2 Wave Antenna

Figure 4
Antenna Placement

1/2 Wave Antenna Placement

If 1/2 wave antennas are mounted directly to the AD-450, they should be configured as shown in Figure 5.

Do not rack mount the AD-450 in this configuration. Serious loss of range and performance may occur.

Place the AD-450 with antennas in a location that is in direct view of the transmitters for best results.

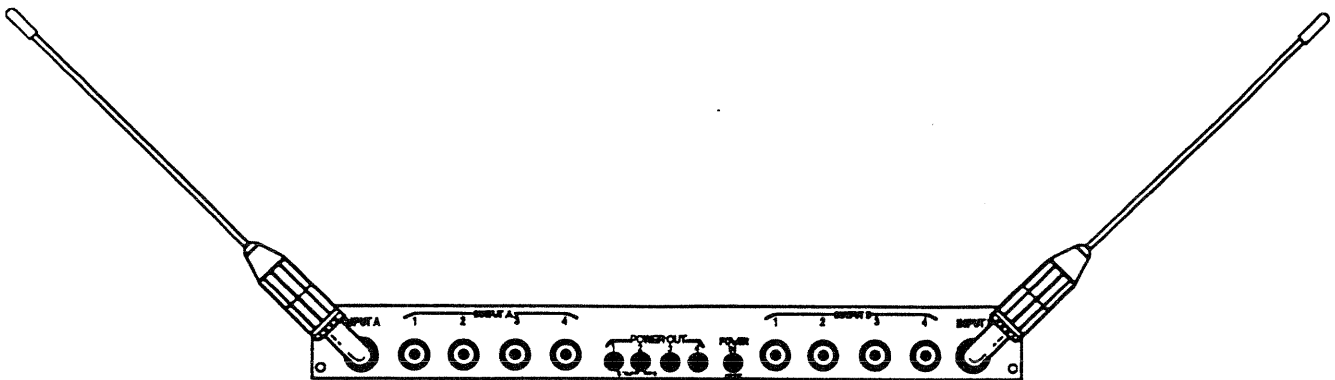

Figure 5
1/2 Wave Antenna Mounting

Antenna Placement for Optimum Range and Rack Mounting

For maximum range and when rack mounting, the antennas must be remotely located.

The ALP-450 comes complete with a variety of mounting hardware and 10 feet (3 meters) of coaxial cable. A combination mounting bracket with 10 feet of coaxial cable is available for the 1/2 wave antenna (Model No. AB-2).

Antennas should be placed in a location with a clear "signal path" to the transmitter. This "path" should be as short and free of obstructions as possible. Obstructions, such as walls ceilings, and metal objects, will reduce range and performance

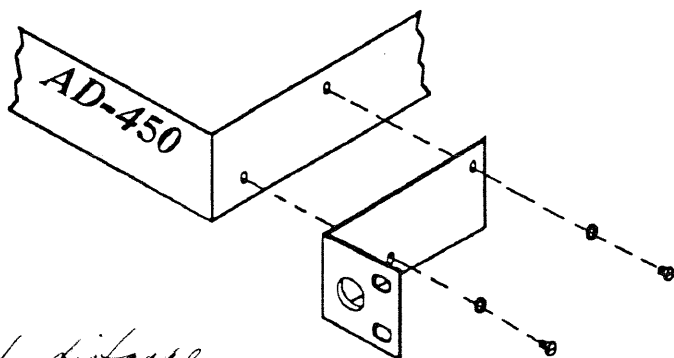

Optimal distance between antennas would be at least 1 ft.

Figure 6
Rack Mounting

ig

Rack mount brackets are supplied with the AD-450. To attach the brackets, proceed as follows:

- Align the rack bracket with the holes on the side of the unit. See Figure 6.
- Install flatwashers and No. 6 screws in two holes. Tighten securely. Repeat on the other side of the unit. For best alignment, perform the above steps while the unit and rack brackets are setting on a flat surface.
- Insert the unit into a 19" rack enclosure and insert four #10-32 x 3/8" Phillips pan head screws (supplied) in each corner of the rack mount brackets and secure.

Rack Mounted Antenna Connectors

Antenna cable connections may be made to the front of the rack mounted AD-450 by installing the adaptor cables supplied. Proceed as follows:

- Remove the plug "knock outs" from the brackets. See Figure 7.
- Install the adaptor cables from the back side of the bracket.
- Tighten the nut and lockwasher securely.
- Attach the other end of the cables to the inputs of the AD-450. Tighten securely.

Front of rack antenna connectors were designed to allow easier hook up of antenna cables. We do not recommend mounting antennas directly to the connectors since performance may be degraded.

Coax Cable

For best results, it is recommended that cable losses be kept under 4 dB. (Every 3 dB of signal loss results in a system operating distance reduction of 25%.

See the accessories section of this manual for special low loss cable assemblies.

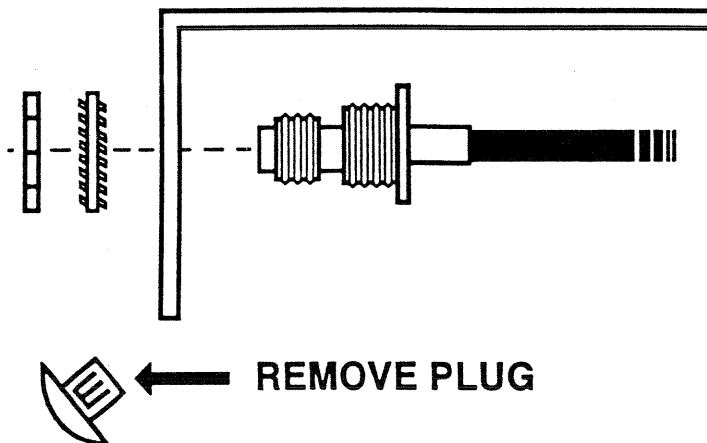
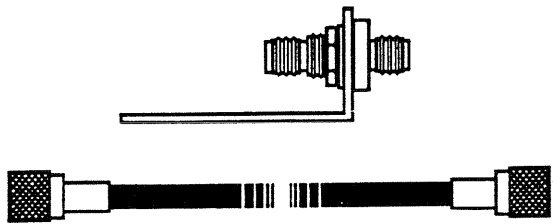
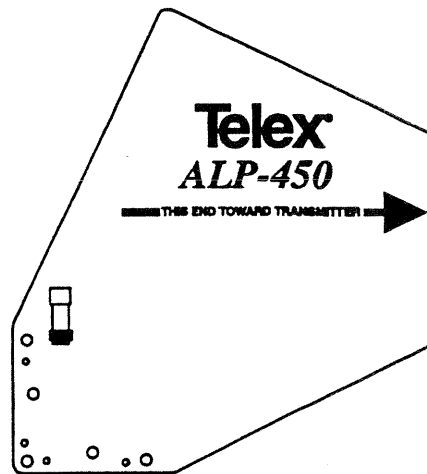

Figure 7
Antenna Connectors

AD-450 Accessories and Replacement Parts



AB-2 Combination
Antenna Bracket and
10 foot (3 meter) coaxial
cable with TNC connectors
Order No. 71138000



ALP-450
450-900 MHz Log Periodic Antenna
Includes mounting hardware and 10 feet (3
meter) coaxial cable with TNC connectors
Order No. 71147000

**Special low loss antenna cables with
TNC connectors**

Length	Order No.
10 Ft. (3 meter)	690419
25 Ft. (7.6 meter)	71151-025
50 Ft. (15 meter)	71151-050
75 Ft. (23 meter)	71151-075
100 Ft. (30 meter)	71151-100

Antenna, 1/2 wave

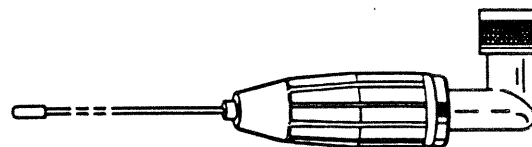

AC Power Supply

Type	Part No.
120V 60 Hz (U.S.)	59224-001
230V 50 Hz (Euro)	730109
230V 50 Hz (U.K.)	730108

TNC dummy load
(For unused outputs)
Part No. 650095

Model No.	Part No.	Band Color	Frequency
CLA-1	870658-1	Blue	520-564.9 MHz
CLA-2	870658-2	Yellow	565-614.9 MHz
CLA-3	870658-3	Red	615-659.9 MHz
CLA-4	870658-4	White	660-689.9
CLA-5	870658-5	Green	690-724.9 MHz
CLA-6	870658-6	Orange	725-760 MHz

AD-450 Cables

Type	Part No.
2 Ft. Coaxial	691459
2 Ft. Power	690396
1 Ft. Coaxial	690401

(For rack Brackets)